

### PNEUMATIC ACTUATOR KIT and PN-MF pneumatic modular systems

The pneumatic actuator kit includes all the components required to run static, dynamic and fatigue tests. It is compatible with RTC 9000 Real Time Controllers.

It can be used for tests conducted with PN-MF (Pneumatic Modular Frame) systems, which are designed and produced by LiTeM. Their high-level modularity means that they can be applied in numerous industrial and manufacturing sectors, such as:

- Plastics
- Footwear
- Springs
- Composite materials
- Biomedical
- Rubber
- Bicycles
- Automotive
- Electronics

PN-MF systems are ideal in all test fields and in particular for Test and Quality Control Laboratories, Universities, Institutes and R&D Centres.

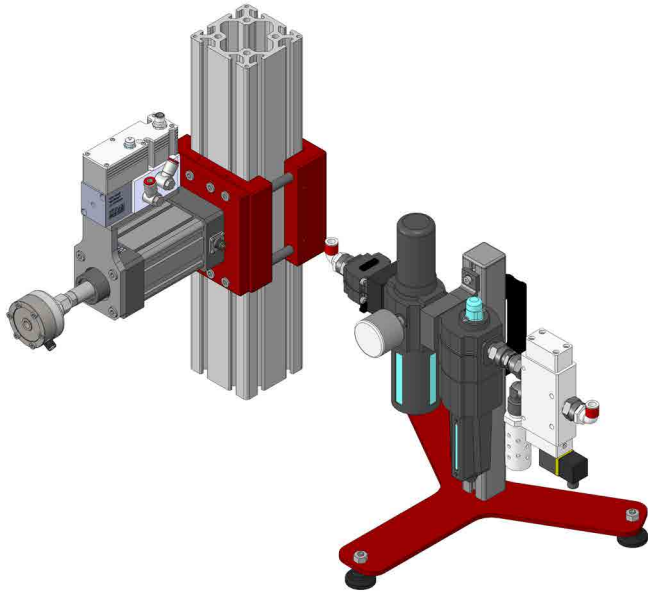

#### K-PN Pneumatic Actuator Kit



OIL FREE



MAXIMUM FLEXIBILITY  
AND CONFIGURABILITY



SIMPLE TO USE



CUSTOMISABLE

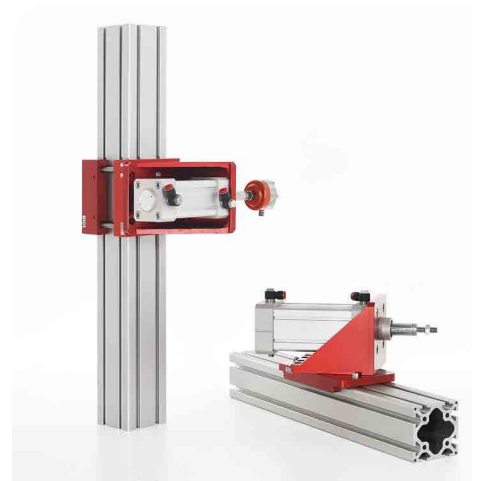
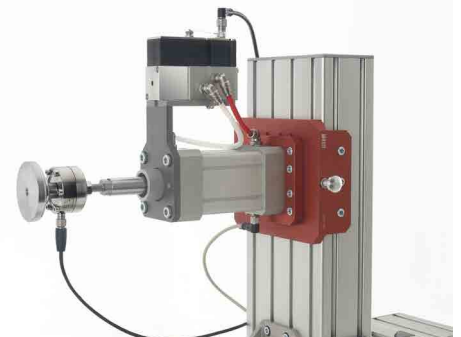

Al fine di migliorare le prestazioni tecniche del prodotto, la società si riserva di apportare variazioni senza preavviso.  
In order to improve the technical performances of the product, the company reserves the right to make any change without notice.

# K-PN Actuator Kit

## Components included in the kit

The pneumatic actuator kit is a flexible, economic and modular solution, perfect for running tests on materials and components of various kinds. It is available in various configurations according to the required stroke and force. The pneumatic kit can be matched to the series of RTC 9000 Real Time Controllers and related command software. The components included in the kit and the related technical specifications are shown in the following tables.

Ref.	Description	Technical specifications
1	Pneumatic actuator complete with built-in contactless displacement sensor.	Male connector M12 4 Poles. Sensor 24 V DC - output 0-10V
2	Proportional servo-valve 5/3 - +/- 5V complete with 5-metre cable assembled on actuator aluminium bracket.	Male connector M12 8 Poles. Power supply 24 V DC - output +/- 5V
3	Class 1 amplified force transducer, complete with 5-metre cable with M12 - DB9 connector, assembled on 303 stainless steel anchorage plate.	Male connector M12 4 Poles. Sensor 24 V DC - output 0-10V
4	Air handling unit complete with shut-off valve, pressure regulator, pressure gauge, filter and pre-filter, on-off solenoid valve, 5-metre 24 V DC power cable.	

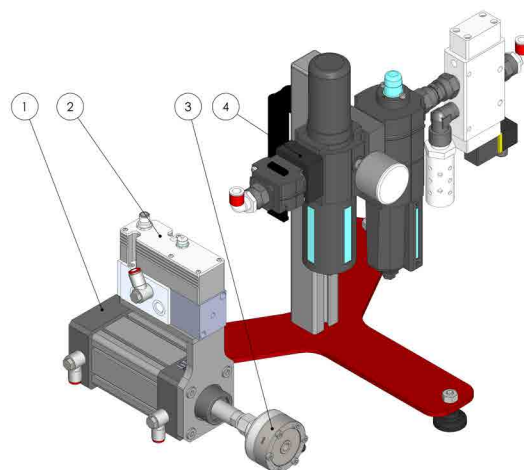

## Order codes

Order codes - Pneumatic Actuator Kit					
TECHNICAL SPECIFICATIONS	K-PN 50-S*/C	K-PN 63-S*/C	K-PN 80-S*/C	K-PN 100-S*/C	K-PN 125-S*/C
Bore	50	63	80	100	125
Static force (6 bar)	1.2	1.8	3	4.5	7.2
Dynamic force (5 bar)	1.1	1.5	2.5	4	6
Available stroke (S*)	50-100-200-250-300-500-1000				
Load cell	1 - 2.5 - 5 - 10 kN				
Servo-valve	Proportional servo-valve 1200 l/min				
Air handling unit	On-off solenoid valve, pressure regulator, manual valve, pressure gauge, pre-filter, 3 micron coalescence filter, cables.				

## Actuator Kit Coding

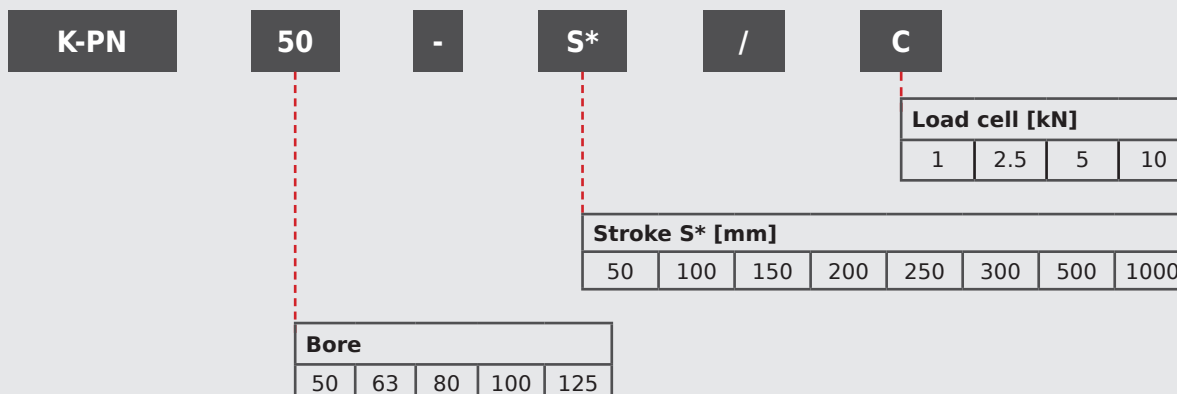

Dimensions - Actuator

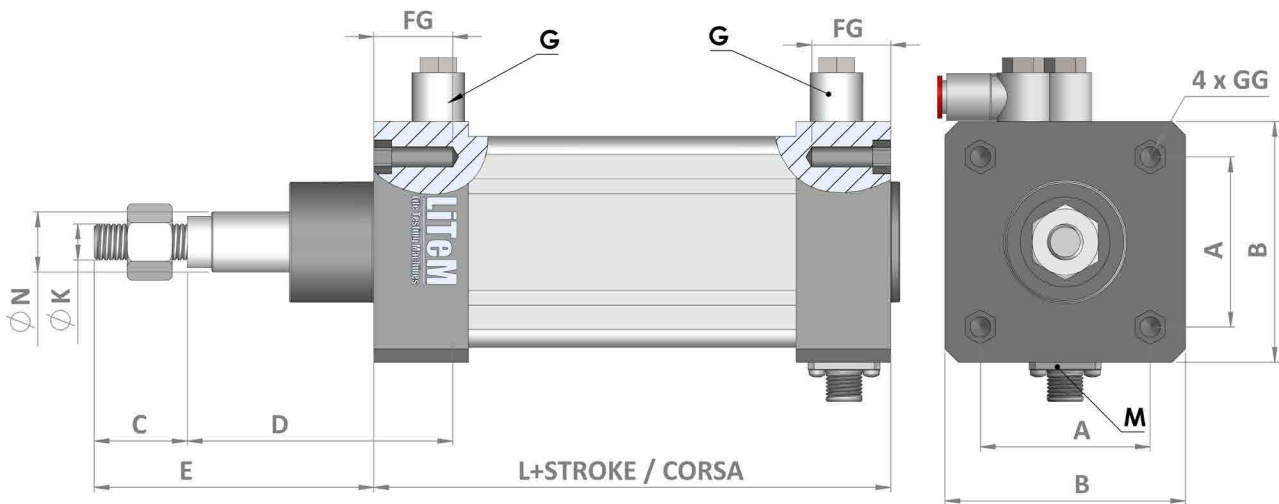

Code	Technical specifications - Actuator											
K-PN	Bore	A	B	C	D	G	N	K	M	L	FG	GG
50	50	46.5	65	32	37	Connector D10-D8	20	M12	M12 4P male	122	16	M8
63	63	56.5	80	32	37		20	M12		233	16	M8
80	80	72	95	40	46		25	M12		128	16	M10
100	100	89	115	40	51		25	M20x1.5		138	16	M10
125	125	110	140	54	65		32	M27x2		160	20	M12

Dimensions - Force Transducer

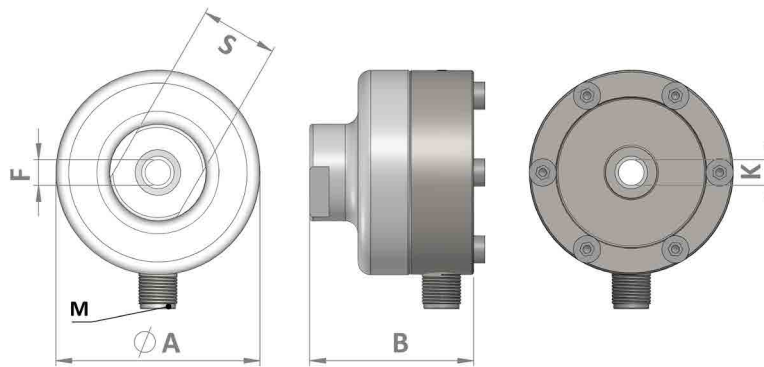

Code	Technical specifications - Force Transducer						
	Max force	A	B	F	K	S	M
LC-1	1 kN	63.5	57.5	M12	M12	24	M12 4P Male
LC-2.5	2.5 kN		57.5	M12		24	
LC-5	5 kN		57.5	M12		24	
LC-10	10 kN		60	M20x1.5		32	
LC-10I	10 kN		60	M27x2		32	

## Accessories

### Actuator body ball coupling

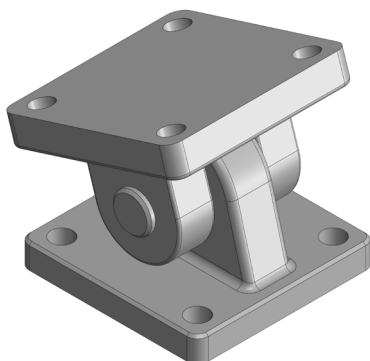

Code	Description
A-SC50	A50 bore actuator ball coupling
A-SC63	A63 bore actuator ball coupling
A-SC80	A80 bore actuator ball coupling
A-SC100	A100 bore actuator ball coupling
A-SC125	A125 bore actuator ball coupling

The rear ball coupling for the actuator body is supplied complete with:

- Ball coupling
- Rear fork plate for coupling
- Rotation pin with lock
- 8 securing screws

### Front ball coupling

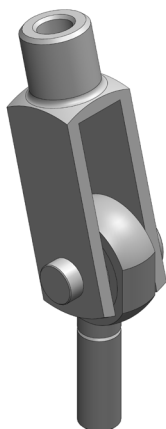

Code	Description
A-SS-12M	Ball coupling kit M12 Male - Fork M12 Female
A-SS-12F	Ball coupling kit M12 Female - Fork M12 Female
A-SS-16M	Ball coupling kit M16 Male - Fork M16 Female
A-SS-16F	Ball coupling kit M16 Female - Fork M16 Female

The ball coupling with fork is supplied complete with:

- Male or female ball coupling M12 or M16
- Fork for ball coupling with M12 or M16 female thread
- Rotation pin with lock
- 2 M12 or M16 lock nuts

### Flat actuator plate

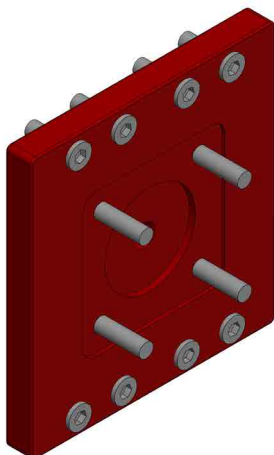

Code	Description
A-PP-50	Rear actuator mounting plate A50
A-PP-63	Rear actuator mounting plate A63
A-PP-80	Rear actuator mounting plate A80
A-PP-100	Rear actuator mounting plate A100
A-PP-125	Rear actuator mounting plate A125

The rear flat plate is supplied complete with:

- Oxidised flat plate
- 4 screws for securing the actuator to the plate
- 8 M8x30 screws for mounting on rear structure

## Rear actuator carriage

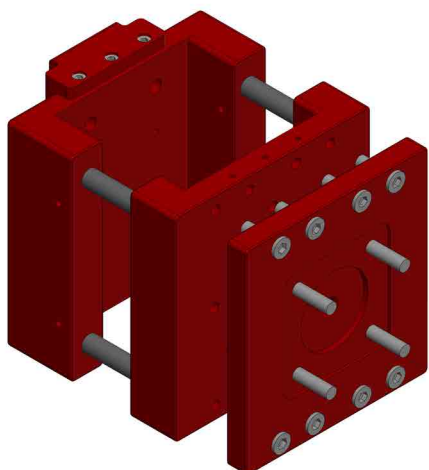

Code	Description
A-CA-4/100	Carriage for actuator plates series A50/63/80/100 - Profile 100
A-CA-4/200	Carriage for actuator plates series A50/63/80/100 - Profile 200
A-CA-6/100	Carriage for actuator plates series A125 - Profile 100
A-CA-6/200	Carriage for actuator plates series A125 - Profile 200

The actuator carriage is supplied complete with:

- Rear locking plate and front interface plate
- Clamping screws M10
- Support bracket for assembled proportional servo-valve

## Actuator anti-rotation system

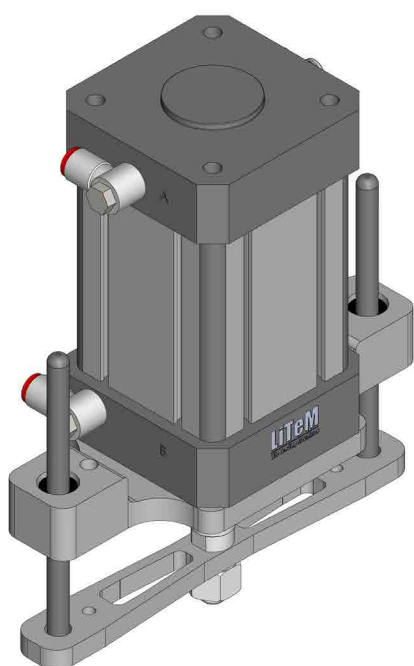

Code	Description
A-AR-50/S*	Actuator anti-rotation system - bore A50 / S*[stroke]
A-AR-63/S*	Actuator anti-rotation system - bore A63 / S*[stroke]
A-AR-80/S*	Actuator anti-rotation system - bore A80 / S*[stroke]
A-AR-100/S*	Actuator anti-rotation system - bore A100 / S*[stroke]
A-AR-125/S*	Actuator anti-rotation system - bore A125 / S*[stroke]

The anti-rotation system kit for the actuator rod is supplied complete with:

- Top support for actuator complete with ball sleeves
- Bottom mobile support for actuator complete with guides

For further information view the component technical sheet:

[www.litem.info/accessori](http://www.litem.info/accessori)

## Related systems

### Real Time Controllers RTC 9000

The pneumatic actuator kit can be connected to the series of RTC 9000 controllers, in the two available versions:

- RTC9001 non expandable single axis
- RTC9000-A modular expandable multi-axis

Further details on: [www.litem.info/controllore](http://www.litem.info/controllore)



### Wave forms that can be generated

- In load or displacement ramp with settable speed
- Cyclical tests with constant amplitude with sinusoidal/triangular/square waves
- Variable amplitude tests with profile defined by the user or importable from an external text file or excel file - requires the activation of the Tools - Profile Editor software licence



### RTC 9001 - Datalogger

The RTC 9001 controller can be used as a data logger with 4 +/-10V input channels and 2 encoders. This function requires the activation of the Tool Scope software licence

### PN-MF Pneumatic Modular Systems

The pneumatic actuator kit can be connected to the series of PN-MF Pneumatic Modular Frames, from the VDC series and BYC series, all designed and produced by LiTeM.

For further information: [www.litem.info/pneumatica/telai-modulari](http://www.litem.info/pneumatica/telai-modulari)

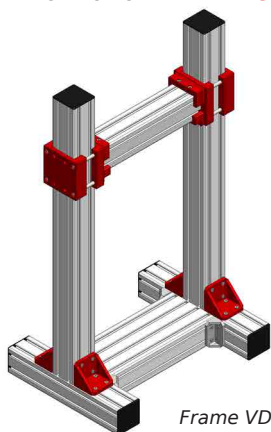

Frame VDC series

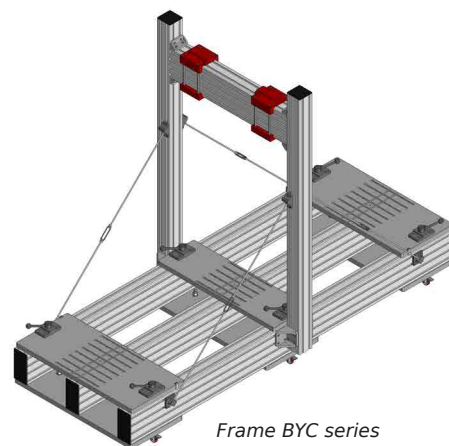

Frame BYC series

Al fine di migliorare le prestazioni tecniche del prodotto, la società si riserva di apportare variazioni senza preavviso. In order to improve the technical performances of the product, the company reserves the right to make any change without notice.

**DRC Srl**  
PRODUCTION and SALES

Via Montesicuro, 58/B - 60131 Ancona (Italy)  
Tel (+39) 071 80 36 077

**GENERAL INFORMATION**  
[info@litem.info](mailto:info@litem.info)

[www.litem.info](http://www.litem.info)