

Handlebar grip - central support for static and fatigue tests

ISO 4210-5

EN 15194

The Handlebar Central Support adapts to all types of stem thanks to the interchangeable coupling

The central pin, the holes and the lateral millings allow the handlebar to be positioned at the appropriate angle for carrying out all the tests required by the ISO 4210-5 EN 15194 standards.

The handlebar grip can slide on the grooved surface allowing a perfect alignment between handlebar under test and actuators.

Compatible with the BYC-200 series frame.

B-BYC-HCS

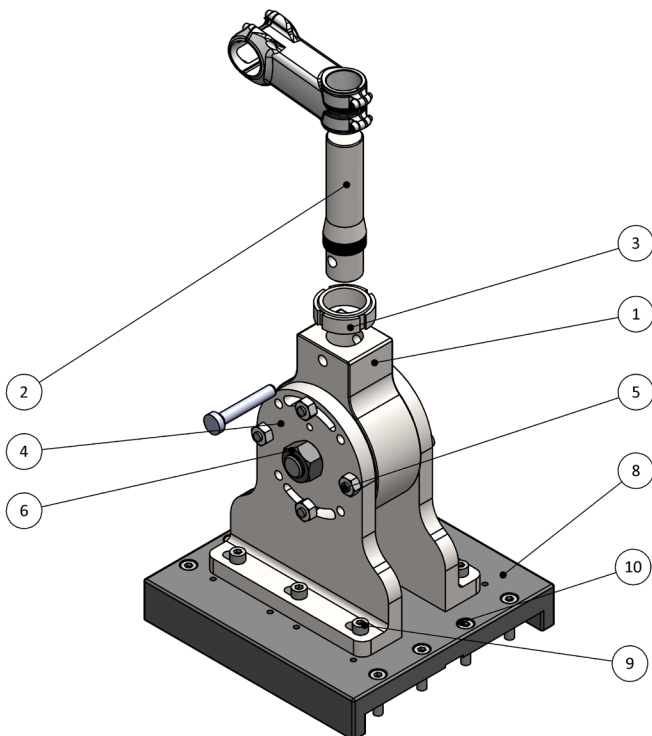

The Kit includes:

1. central pin
2. stem/tube - interchangeable coupling
3. closing ring
4. side milled flanges
5. tightening screws
6. central rotation and tightening pin
8. interface plate
9. fixing screws
10. fastening and sliding screws

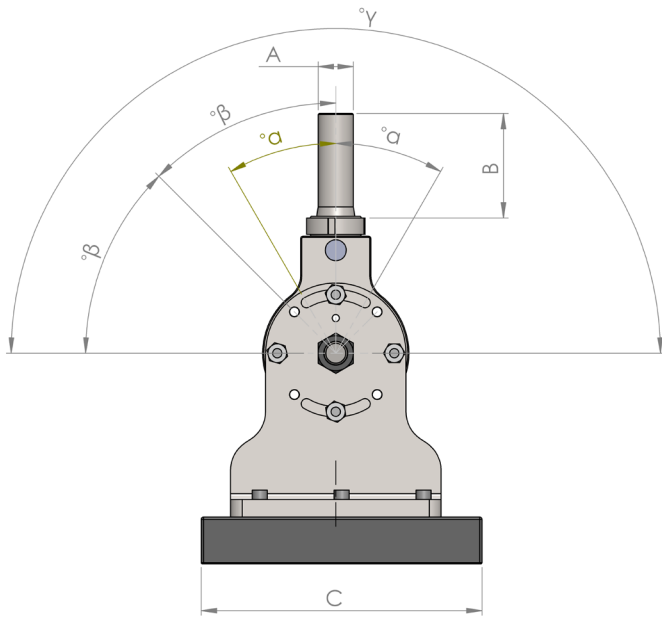

Inclination angles

The central support allows the rotation of the pin between + 90 ° and -90 °. Thanks to this possibility, the handlebar under test can always be positioned in the most correct configuration for each of the tests required by UNI 4210-5 and EN 15194.

Angles between + 30 ° and -30 ° are continuously selectable. The angles + 45 °, -45 °, + 90 ° and -90 ° are discretely selectable.

Rif.	Dimensions [mm]*
A	30
B	90
C	240

Rif.	Angles [°]*
α	30
β	45
γ	180

Modularity and safety of fixing

The central pin allows to anchor any type of stem and the closing ring guarantees a stable and safe fixing for each type of test.

The central rotation and tightening pin and the tightening screws allow a stable and safe positioning even for the heaviest test loads.

The central support can slide on the grooved surface allowing precise positioning of the handlebar under test in correspondence with the actuators.

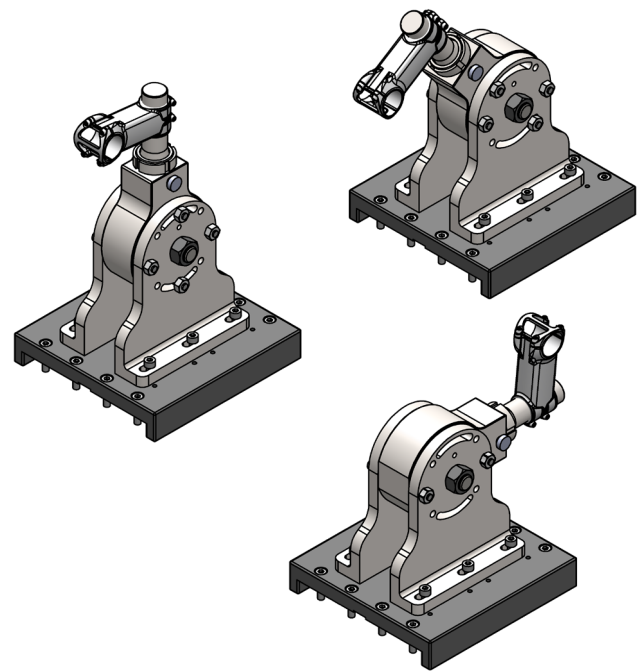

* Available in different sizes made according to customer specifications

Al fine di migliorare le prestazioni tecniche del prodotto, la società si riserva di apportare variazioni senza preavviso. In order to improve the technical performances of the product, the company reserves the right to make any change without notice.

DRC Srl
PRODUCTION AND SALES
Via Montesicuro, 58/B - 60131 Ancona (Italy)
Tel (+39) 071 80 36 077

EnginLAB Srl
RESEARCH AND DEVELOPMENT
Via Verità 3/a - 35131 Padova (Italy)
Tel (+39) 049 20 21 489

GENERAL INFORMATION
info@litem.info

www.litem.info