

Clamps for static and fatigue tests - aerodynamic extension torsional security test ISO 4210-5: part 4.8

Clamping kit for running static and fatigue tests both mono-axial and bi-axial on bicycle handlebar. Compatible with the BYC-200 series frame.

The Kit includes:

- extension for actuators (3 different lengths)
- pair of thrusters with spherical seat

Extension for actuators

Extensions are used to connect the actuator stem to the handlebar or component under test. The load cell and the thrusters with spherical seat complete the gripping set-up.

The three different lengths allow to grip handlebars of different sizes without necessarily having to change the position of the BYC-200 frame crossbar.

Rif.	Dimensions [mm]*
L	150 - 200 - 250
S	17
D	20
F	M12x1.75
W	M12x1.75

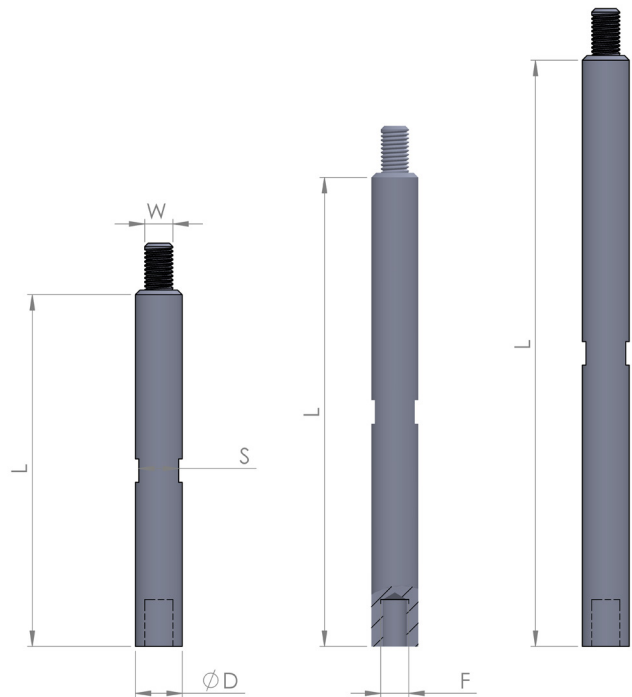

* Available in different sizes made according to customer specifications

Al fine di migliorare le prestazioni tecniche del prodotto, la società si riserva di apportare variazioni senza preavviso. In order to improve the technical performances of the product, the company reserves the right to make any change without notice.

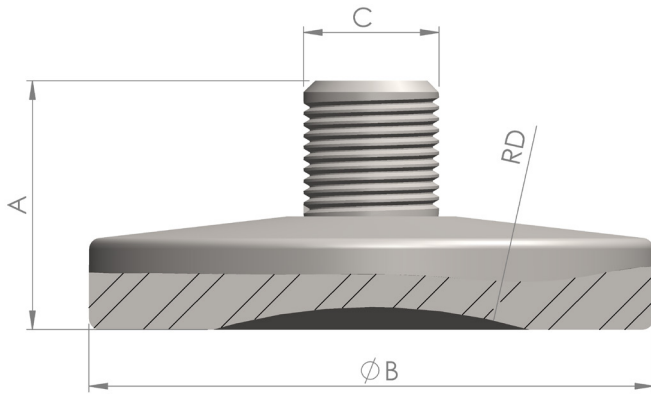

Thrusters with spherical seat

The thrusters with spherical seat allow to adapt to the different shapes and sizes of the handlebar extensions.

Rif.	Dimensions [mm]*
A	22
B	50
C	M12x1.75
RD	50

Spherical seat

The spherical seat guarantees the application of perfectly axial loads even in the case of extensions with ergonomic terminals.

The spherical seat also protects the actuator stem from harmful lateral loads.

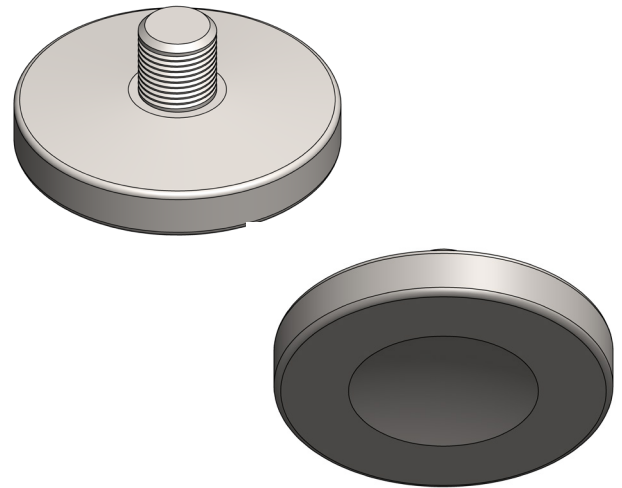

* Available in different sizes made according to customer specifications

Al fine di migliorare le prestazioni tecniche del prodotto, la società si riserva di apportare variazioni senza preavviso.
In order to improve the technical performances of the product, the company reserves the right to make any change without notice.

DRC Srl
PRODUCTION AND SALES
Via Montesicuro, 58/B - 60131 Ancona (Italy)
Tel (+39) 071 80 36 077

EnginLAB Srl
RESEARCH AND DEVELOPMENT
Via Verità 3/a - 35131 Padova (Italy)
Tel (+39) 049 20 21 489

GENERAL INFORMATION
info@litem.info

www.litem.info